

Quality is more than a word

ESPEC

Advanced Battery Tester



Introducing the All-in-One Secondary Battery Charge-Discharge Evaluation System

With advances in environmental technology, secondary battery applications have become greatly diversified. Secondary batteries of various capacities, shapes and specifications are being developed for wide-ranging applications from mobile devices to industrial equipment and automotive devices.

Secondary batteries are increasingly important in our modern low-carbon society and ever more stringent performance demands such as miniaturization and higher density are placed on them, particularly in automotive applications.

Moreover, as new component materials for secondary batteries are developed, a wide variety of specifications is being required of charge-discharge cycle (characteristic) testing for evaluating the characteristics of batteries and materials. These specifications are changing on a daily basis.

The Advanced Battery Tester is an entirely new type of charge-discharge test system in which the charge-discharge system and chamber have been designed as a whole. The four functions (performance testing, durability testing, temperature characteristic testing and impedance evaluation), which are essential to maximizing the battery characteristic evaluation functions, are implemented in a single tester.

ADBT-S (Single-chamber single type)



ADBT-T (Three-chamber multi type)



Characteristics

Integration of a Specially Designed Chamber and System Patent pending

● Four functions in one unit

Multiple functions including performance testing, durability testing, temperature characteristic testing and impedance evaluation (option) are included in this compact tester. A single tester can flexibly meet a wide variety of testing needs.

● Cableless design

There are no more bundles of cables passing between the chambers and the power supply system, making the periphery of the tester clean. This design means reduction of time and labor in connecting cables, allowing you to install and start testing quickly. Also this design reduces the voltage drop that occurs due to the wire resistance in cables to a minimum.

● Space saving

The integration of the chambers and the power system in a single structure has drastically reduced the overall size. The space previously needed for running cables around the chambers is no longer necessary, reducing the required footprint. In addition, the extra space needed inside the chamber for running cables is also reduced, allowing more samples to be placed in the chamber.

● Reduced cost of ownership

The elimination of cables has minimized the power supply system loss. This reduces power consumption and also the construction costs for installation. The three-chamber (two-chamber) type includes only one refrigerator in each tester. Compared with three chambers (two chambers) of the same size, the amount of electricity consumed is reduced.

● One call does it all

ESPEC now designs and manufactures the entire tester including the chambers and the power system. In the rare event of a failure, one call to our distributor or our sales staff will take care of you.

● Structural drawing

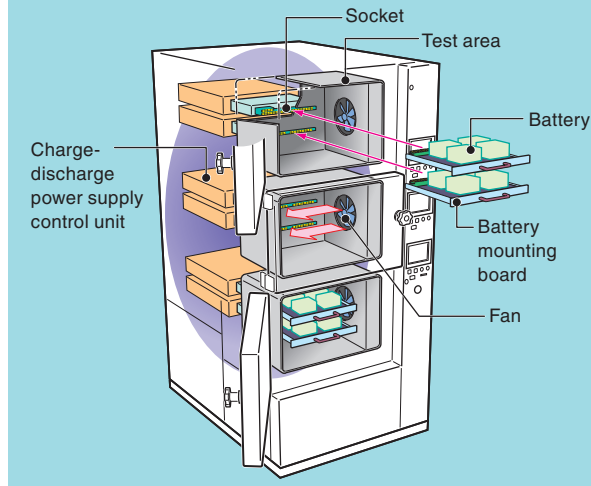

● Space saving

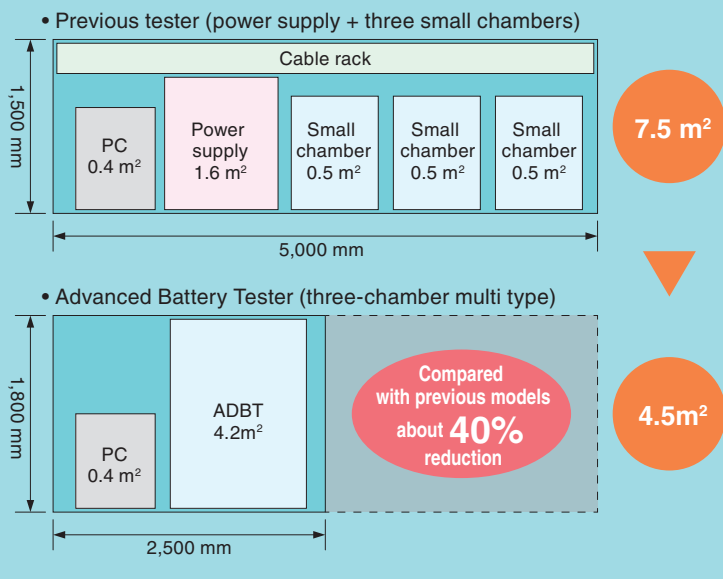

● Wiring length vs. voltage drop

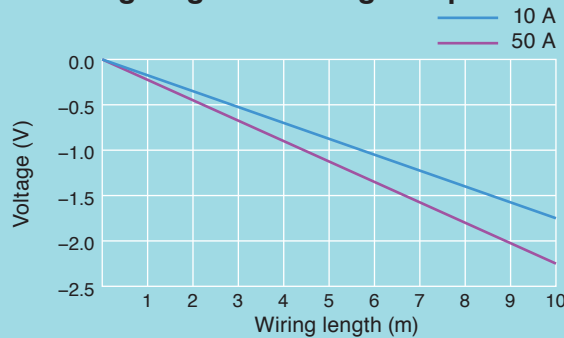

Characteristics

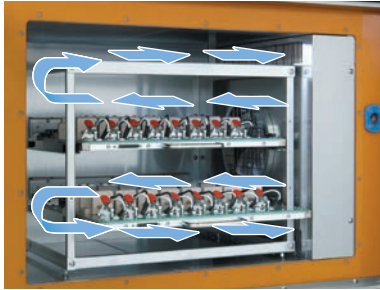

Three-chamber and two-chamber types



Single-chamber type

Chamber

Horizontal air flow

The chambers come with a built-to-engineered rack specifically designed to meet your requirements. This design allows air to flow horizontally even with batteries in place, resulting in better temperature distribution.

The air will flow from right to left for the 2 and 3 chamber types, and back to front for the single chamber type.

This much improved temperature distribution compared to the conventional flow makes highly repeatable charge-discharge tests possible.

Safety devices (option)

Numerous safety features are available.

Power supply system

Flexibility

The current range can be expanded through the parallel operation of the power supply system, enabling this tester to support high-current tests and high-rate tests. The power supply system is available in five types: 1 A, 10 A, 50 A, 400 A and 600 A. Different types of power supply systems can be mixed in a single tester. It is also possible to change only the power supply system at a later date.

Impedance measurement function (option)

Impedance can be measured at a specific cycle in a charge-discharge cycle test. Measurements can be taken continuously without removing the batteries, and highly reliable data can be obtained thanks to the cableless design. Furthermore, errors between channels is minimized because the internal wiring length between channels is fixed due to the use of battery mounting boards.

Temperature transition comparison

- Previous tester (our temperature and humidity chamber)
- ADBT

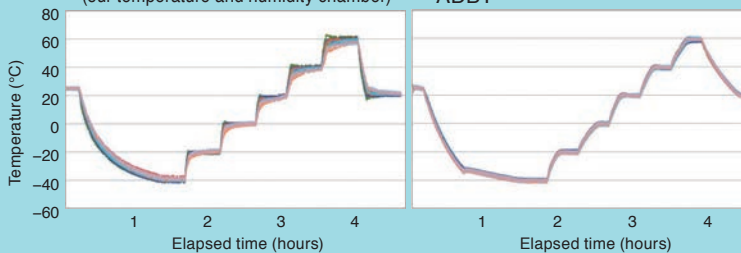

Test conditions:
 Temperature setting $-40^{\circ}\text{C} \rightarrow -20^{\circ}\text{C} \rightarrow 0^{\circ}\text{C} \rightarrow +20^{\circ}\text{C} \rightarrow +40^{\circ}\text{C} \rightarrow +60^{\circ}\text{C}$
 (stable over 30 minutes at each setting)
 Measurement Install dummy batteries in three shelves in the test area.
 5 test points in each shelf + 5 test points near the base for a total of 20 test points

Impedance measurement example: Cole-Cole plot (Correlation with temperature)

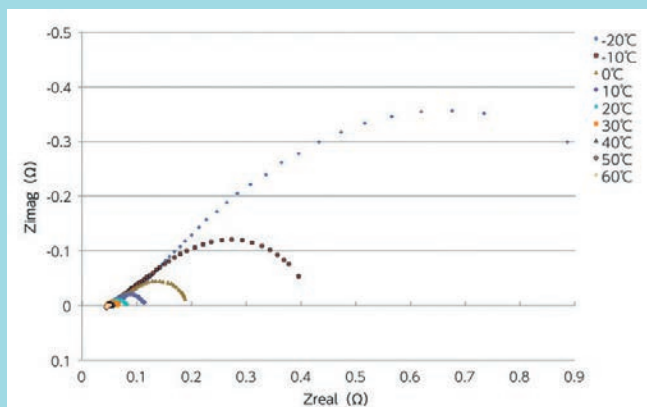

Characteristics

Battery mounting board

● Tailor-made

Coin, laminated, cylindrical, and rectangular cells of different sizes are supported and can be mounted in a multi-channel setup. The battery shape, orientation, clamp type, quantity, layout and airflow will be considered when designing the board.

● Cell temperature measurement

For each channel, the battery mounting board is equipped with a thermocouple for measuring the battery cell temperature. In addition to recording the temperature of each cell, two levels of temperature alarms (protection) can be set.

● Safe and easy test preparation

The tailored board can be detached from the chamber, which enables you to work at a desktop, away from the chamber. This design allows you to prepare for a test in easy three steps:

1. Pull out the board and put it on a table top.
2. Place the batteries.
3. Put the board back on the guide rail and push it back all the way.

In addition, this separate design increase the safety of operators. Whenever the operator places or replaces the batteries, the board will be disconnected from the power supply, eliminating the chance of electrocution.

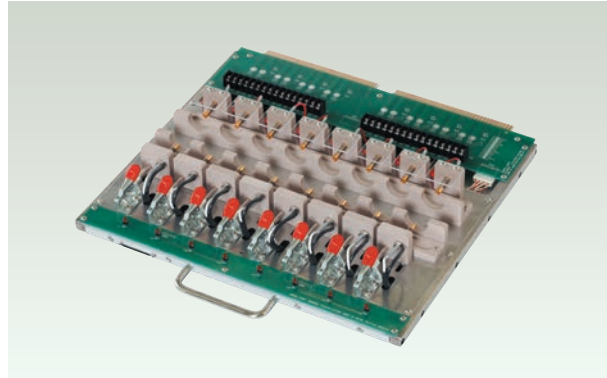

Battery mounting board for cylindrical cells

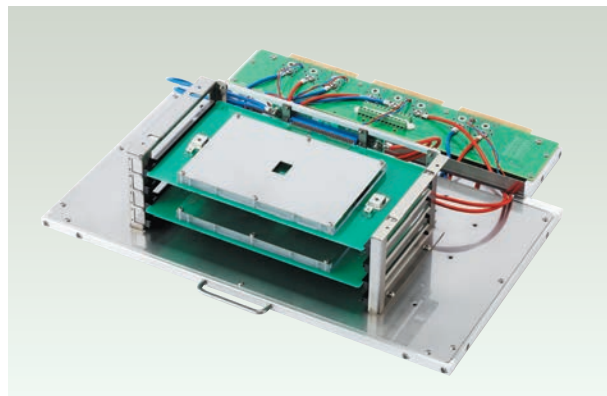

Battery mounting board for laminated cells

Power supply system calibration

● Automatic calibration board (option)

ESPEC provides automatic calibration boards so that you can perform calibration whenever necessary. By simply setting the auto calibration board in place of the battery mounting board, you can easily perform automatic diagnosis and automatic calibration on each channel by selecting the mode on the PC application.

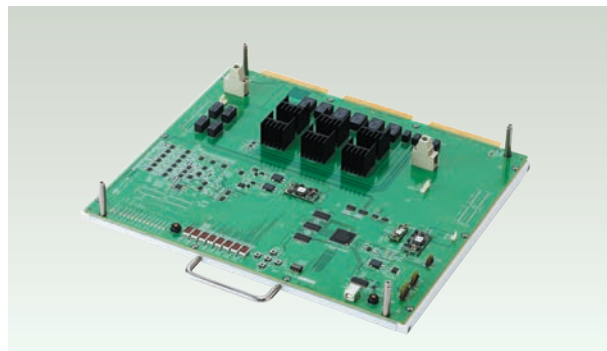

Automatic calibration board

● Traceability

The automatic calibration board is traceable to Japanese national standards and calibrated according to ESPEC calibration procedures. Each board is shipped with a traceability system diagram and calibration certificate.

Characteristics

● Test program configuration

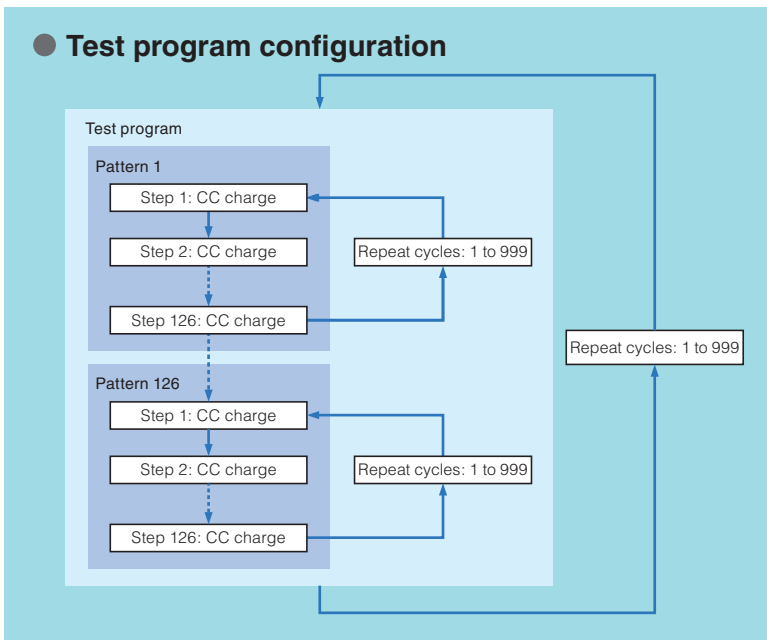

Software

● Test program configuration

The system is standard equipped with charge-discharge test modes (CC charge-discharge, CV charge, CC-CV charge, CP charge-discharge, pulse and standby). You can set the test mode for each step and combine the steps to create a pattern that can be registered. Furthermore, several patterns can be combined to create a wide variety of test conditions. In each step, you can combine various transition conditions including voltage, current and time to specify how to transition to the next step. A test pattern can be looped up to 999 times.

● Operation status monitoring

Step	CH	Group	Test No.	Result Folder	Test Start Time	Test End	CH Status	STATUS	RANK#	MOX#	I-Time	I-Cnt	P-Mode	P-Name	P-Cnt	P-Time	S-Time	S-Cnt	S-Mode	S-Name	S-Cnt	S-Time	S-Mode	S-Name
1	2	1	1001	1001	2012/12/20 09:58:32	1-1	PASS	0001	10A		1922617	1	4.demod	16	1406918	528	2	4.200	0.000		44.8			
2	1	1	1001	1001	2012/12/20 09:58:50	1-2	PASS	0001	100mA		1922728	1	4.demod	14	1201922	1468	1	3.744	90.011		44.4			
3	3	1	1001	1001	2012/12/20 09:58:52	2-1	PASS	0001	100mA		1922529	1	4.demod	14	1201742	96	3	4.115	89.981		44.2			
4	4	1	1001	1001	2012/12/20 09:58:52	2-2	PASS	0001	100mA		1922527	1	4.demod	14	1205927	2465	3	3.426	89.981		44.4			
5	5	1	1001	1001	2012/12/20 09:58:54	3-1	PASS	0001	100mA		1922513	1	4.demod	15	1420747	2511	2	3.949	89.980		44.3			
6	6	1	1001	1001	2012/12/20 09:58:59	3-2	PASS	0001	100mA		1922501	1	4.demod	16	1505819	2501	1	4.500	90.011		44.3			
7	7	1	1001	1001	2012/12/20 09:59:45	4-1	PASS	0001	100mA		1922445	1	4.demod	17	1550924	1816	1	3.807	90.010		44.3			
8	8	1	1001	1001	2012/12/20 09:59:59	4-2	PASS	0001	10A		1922421	1	4.demod	16	1547261	2987	4	3.198	0.000		44.9			
9	9	1	1001	1001	2012/12/20 10:00:12	5-1	PASS	0001	100mA		1922318	1	4.demod	17	1557019	174	3	3.847	89.992		44.2			
10	10	1	1001	1001	2012/12/20 10:00:20	5-2	PASS	0001	100mA		1922309	1	4.demod	18	1655522	4232	1	4.200	4.399		44.4			
11	11	1	1001	1001	2012/12/20 10:00:30	7-2	PASS	0001	100mA		1922256	1	4.demod	18	1665125	1405	2	3.707	90.011		44.2			
12	12	1	1001	1001	2012/12/20 10:01:00	8-1	PASS	0001	100mA		1922206	1	4.demod	20	1806020	2738	1	4.200	11.753		44.1			
13	13	1	1001	1001	2012/12/20 10:01:00	8-2	PASS	0001	100mA		1922205	1	4.demod	14	1484694	2072	2	4.414	90.010		44.4			
14	14	1	1001	1001	2012/12/20 10:01:00	8-3	PASS	0001	100mA		1922211	1	4.demod	16	1490020	2247	1	3.970	90.010		44.1			
15	15	1	1001	1001	2012/12/20 10:01:00	9-1	PASS	0001	100mA		1922143	1	4.demod	15	1484902	2554	2	3.703	89.990		44.2			
16	16	1	1001	1001	2012/12/20 10:01:00	9-2	PASS	0001	10A		1101195	1	2.demod	2	20099	0	0	0.000	0.000		44.2			
17	17	1	1001	1001	2012/12/20 10:01:00	10-1	PASS	0001	10A		1922101	1	4.demod	14	1380169	1244	4	3.157	0.000		44.5			
18	18	1	1001	1001	2012/12/20 10:02:00	11-1	PASS	0001	100mA		1922101	1	4.demod	17	154793	60	1	3.944	90.013		44.1			

● Test pattern editing

Step No.	Test Mode	Voltage (V)	Current (A)	Electric Power (W)	Step Shift Time	Step Shift Ratio (%)
1	CC charge	3	3	9.000000		0.1
2	CC-Discharge		1	3.000000		60
3	Rest			0.000000		
4	CC-CV charge	4	3	12.000000		1

● Test step editing

The Test Step Editing window allows for detailed configuration of a test step. It includes fields for Voltage, Current, Electric Power, and Step Shift Time. There are also checkboxes for various conditions like Temperature, Step Shift Condition, Delay Time, Cell Volt. B, Cell Volt. R, Cell Volt. L, and Cell Volt. Sense. A Sleeping checkbox is also present.

● Graph editing

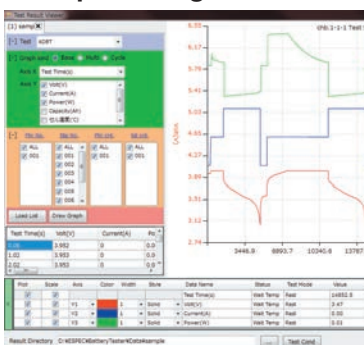

● Cycle performance graph

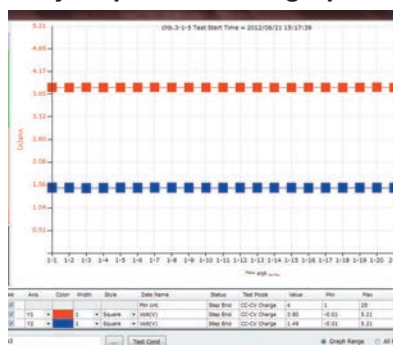

● Graph function

The x-axis and y-axis can be set freely, and a secondary y-axis is also available. Superposition of multiple data sets as well as cycle graphs with pattern repetitions assigned to the x-axis are also supported. In addition, a zoom function controlled through the mouse wheel, bitmap exporting of graph images and other data analysis functions are available.

● Test program synchronization

A function for synchronizing the chamber and the power supply system is provided as a standard feature. You can specify a temperature setting in a test to synchronize the charge-discharge test with the temperature or perform independently.

Characteristics

● Pulse control

Charge-discharge pulse test profile can easily be programmed by using CSV format.

● Touch panel controller (option)

By using the touch panel controller, you can start, stop and perform other test operations locally. The touch panel screen provides an icon interface. The operator can control test operations through this graphical interface.

● All channel monitoring



● Each channel monitoring



Network

● Ethernet connection (option)

From a PC (remote PC) connected to the tester through a LAN, you can monitor the tester status, create test conditions, and view test results data.

You can assign a remote PC as a server PC, connect it to multiple testers, and collectively control the entire system. Test conditions and result data are saved to the server PC's storage. Controller PCs and remote PCs can connect to the server over the network and load test conditions and record results data.



The server PC and remote PCs can be used to perform the same functions as controller PCs except for the tester control operations (setting test conditions; starting, stopping and resuming tests; and controlling chambers).

Furthermore, the tester can be flexibly modified to integrate into the communication network of your host system.

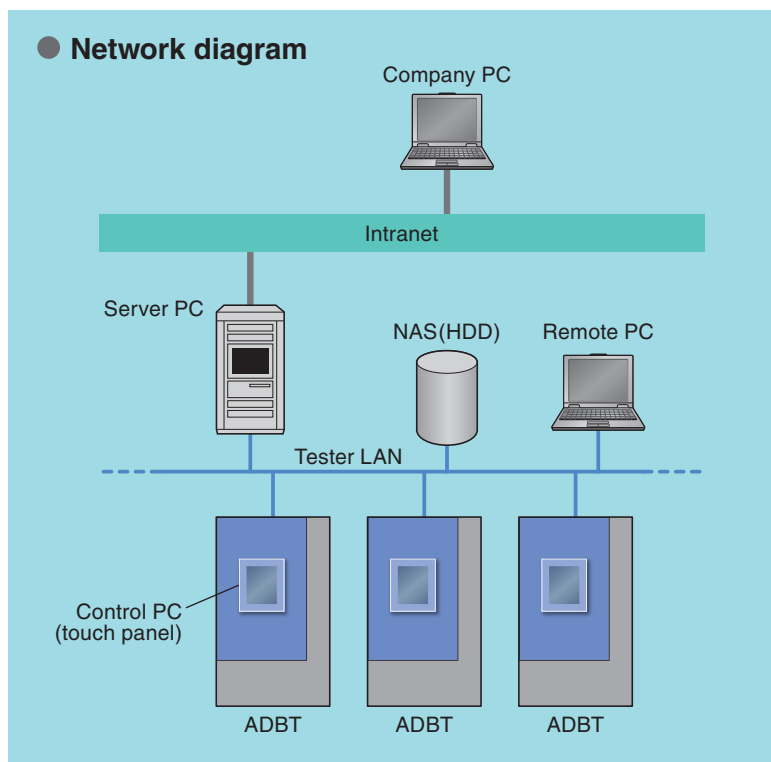
● Network diagram

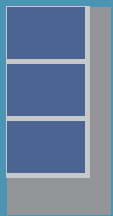

SYSTEMS

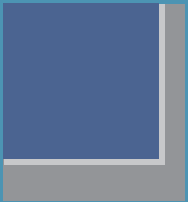
Type		Three-chamber	Two-chamber	Single-chamber	Wide single-chamber
					
Interior dimensions (mm)		W 510 H 400 × 3 chambers D 400	W 510 H 400 × 2 chambers D 400	W 640 H 850 D 544	W 1110 H 850 D 544
Outside dimensions (mm)		W 950 H 2022 D 1300	W 950 H 1522 D 1300	W 1250 H 1875 D 1560	W 1720 H 1875 D 1560
ADBT-5-1	5 V, 1 A	72ch (24ch/chamber)	48ch (24ch/chamber)	72ch	144ch
ADBT-5-10	5 V, 10 A	72ch (24ch/chamber)	48ch (24ch/chamber)	72ch	144ch
	5 V, 16 A (2-unit parallel control)	36ch (12ch/chamber)	24ch (12ch/chamber)	36ch	72ch
	5 V, 32 A (4-unit parallel control)	18ch (6ch/chamber)	12ch (6ch/chamber)	18ch	36ch
ADBT-5-50	5 V, 50 A	24ch (8ch/chamber)	16ch (8ch/chamber)	24ch	48ch
	5 V, 80 A (2-unit parallel control)	12ch (4ch/chamber)	8ch (4ch/chamber)	12ch	24ch
	5 V, 160 A (4-unit parallel control)	6ch (2ch/chamber)	4ch (2ch/chamber)	6ch	12ch
	5 V, 320 A (8-unit parallel control)	3ch (1ch/chamber)	2ch (1ch/chamber)	3ch	6ch
ADBT-5-400	5 V, 400 A	3ch (1ch/chamber)	2ch (1ch/chamber)	3ch	6ch
ADBT-5-600	5 V, 600 A	3ch (1ch/chamber)	2ch (1ch/chamber)	3ch	6ch

STANDARD SPECIFICATIONS

Model		ADBT-5-1	ADBT-5-10	ADBT-5-50	ADBT-5-400
Test area	Control range	-40°C to +100°C			
	Temperature distribution	±1.5°C			
Output voltage	Setting range	0 to 5000 mV			
	Output accuracy	±0.1% of F.S.			
Output current	Setting range	0 to 1 mA 0 to 10 mA 0 to 100 mA 0 to 1000 mA/1 A	0 to 100 mA 0 to 1000 mA/1 A 0 to 10000 mA/10 A	0 to 500 mA 0 to 5000 mA/5 A 0 to 50000 mA/50 A	0 to 50 A 0 to 200 A 0 to 400 A
	Output accuracy	±0.1% of F.S.			
Output power	Setting range	0 to 5 W	0 to 50 W	0 to 250 W	0 to 2000 W
	Output accuracy	±0.2% of F.S.			
Parallel connection function	2 units	—	16 A	80 A	—
	4 units	—	32 A	160 A	—
	8 units	—	—	320 A	—
Measurement points	Current/Voltage	Current: 1 point per channel / Voltage (specimen edge): 1 point per channel			
	Temperature	1 point per channel		2 points per channel	2 points per channel

* Requires separate battery holder for use with parallel connection.

* Dedicated for 8-unit parallel connection. Cannot be used with non-parallel, 2-unit parallel, or 4-unit parallel connections.

SOFTWARE FUNCTIONS

Test condition settings	Structure	Test program: 126 patterns, 999 repetitions max. Pattern: 126 steps, 999 repetitions max.
	Temperature operation	Temperature synchronous operation, temperature asynchronous operation
	Test modes	CC/CV/CC-CV/CP charging, CC/CP discharging, pulse, standby
	Setup items	Measurement range, current, voltage, power, temperature, etc.
	Step transition conditions	Time, current, voltage, power, capacity, etc.
Test operation		Start, stop, force stop (can be executed at the channel level)
Test result display		Detailed data display, graph display (displayed items can be specified), CSV output
Other functions		Test area control, test log, trouble log, operator registration, etc.

MODEL

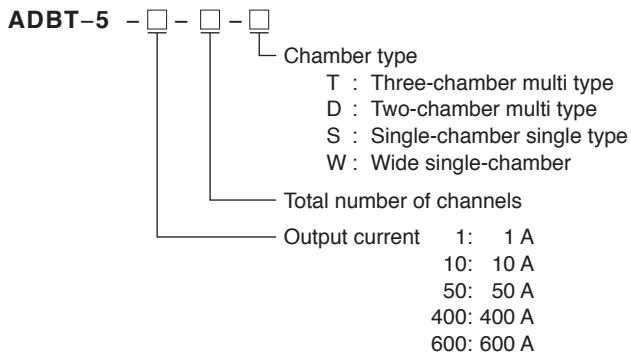

ACCESSORY

- User's manual (booklet, CD)..... 1 set
- Host PC set
- Application software
(pre-installed in host PCs)
- USB cable (for PC and control unit communication)
- Cable port rubber plug (ø50 mm silicon sponge rubber)
- Battery mounting board
- Shipment inspection report..... 1 set

SYSTEM CONFIGURATION

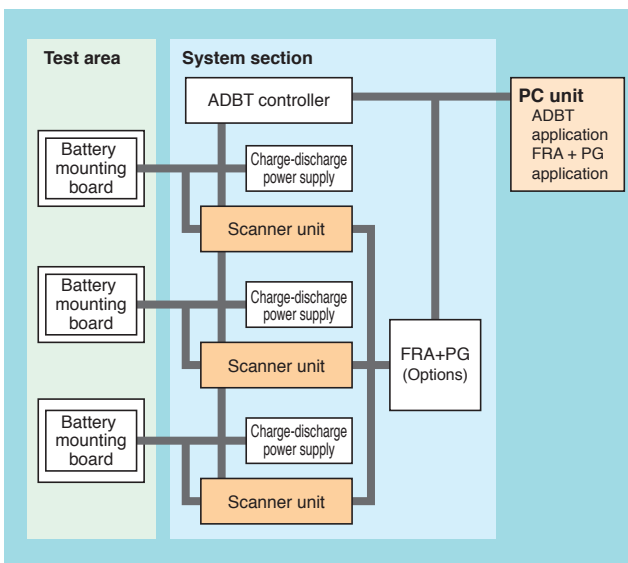

OPTIONS

Chamber

Pressure relief vent

Releases pressure to reduce explosive power.

Installation location:

Left side of the test area (T type, D type)

Ceiling of the test area (S type, W type)

* The vent does not guarantee safety against explosions.



CO₂ fire extinguisher

Starts automatically when a fire (abnormal heat generation) is detected in the test area to extinguish the fire.



Safety device triggers

- Heat detector
- Smoke detector
- H₂/CO/organic gas detector

* Triggers may be combined.

Forced air supply-exhaust mechanism

Reduces the gas concentration in the test area by forcing the air out of the test area. This mechanism can be synchronized with other types of gas detectors.

Anchoring fixtures

Used to fix the chamber to the floor.

Status indicator light

You can select the light color, whether the light turns on solidly or flashes, and whether to include a buzzer.



Refrigeration circuit water-cooled system

Changes the condenser of the refrigeration system to water cooling in order to reduce the effect of heat exhaust.

Power key switch

Used to manage/restrict chamber usage.



Water-cooled refrigeration

To reduce the effect of exhaust heat, this option changes the refrigeration system to a water-cooled condenser.

Frost-free circuit

Prevents frost from accumulating on the refrigeration circuit to allow long-term continuous operation.

OPTIONS

Power supply system

High speed switching

Supports high-speed charge-discharge switching for automotive charge-discharge tests and other similar tests.

8-unit-parallel, high-current control

Eight 50 A power supplies can be controlled in parallel to support automotive charge-discharge tests and other similar tests that require up to 360 A. In addition, a 400 A lineup and a 600 A lineup have been added to meet your high-current testing needs.

Impedance measurement function

Measures impedance at a specific charge-discharge cycle.

Battery mounting board

Battery mounting board for parallel connection

When the battery mounting board for parallel control is used, the system recognizes its ID and enables parallel control of the power supply systems.

Custom battery mounting boards

Dedicated custom battery mounting boards can be provided depending on the cell shape and size that you need.

Other options

Automatic calibration board

Enables you to perform automatic diagnosis and automatic calibration at the channel level.

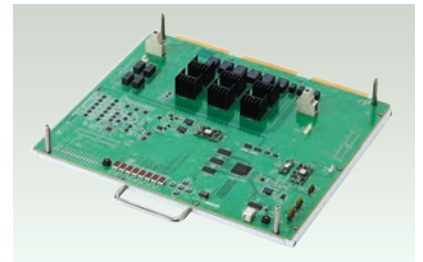

Network

A network of multiple Advanced Battery Testers can be constructed.

ESPEC CORP. <http://www.espec.co.jp/english>

Head Office

3-5-6, Tenjinbashi, Kita-ku, Osaka 530-8550, Japan
Tel: 81-6-6358-4741 Fax: 81-6-6358-5500

ESPEC NORTH AMERICA, INC.

Tel: 1-616-896-6100 Fax: 1-616-896-6150

ESPEC EUROPE GmbH

Tel: 49-89-1893-9630 Fax: 49-89-1893-96379

ESPEC ENVIRONMENTAL EQUIPMENT (SHANGHAI) CO., LTD.

Head Office

Tel: 86-21-51036677 Fax: 86-21-63372237

BEIJING Branch

Tel: 86-10-64627025 Fax: 86-10-64627036

TIANJIN Branch

Tel: 86-22-26210366 Fax: 86-22-26282186

GUANGZHOU Branch

Tel: 86-20-83317826 Fax: 86-20-83317825

SHENZHEN Branch

Tel: 86-755-83674422 Fax: 86-755-83674228

SUZHOU Branch

Tel: 86-512-68028890 Fax: 86-512-68028860

ESPEC TEST TECHNOLOGY (SHANGHAI) CO., LTD.

Tel: 86-21-68798008 Fax: 86-21-68798088

ESPEC SOUTH EAST ASIA SDN.BHD.

Tel: 60-3-8945-1377 Fax: 60-3-8945-1287



ISO 14001 (JIS Q 14001)
Environmental Management System Assessed
and Registered
ESPEC CORP.

- Specifications are subject to change without notice due to design improvements.
- Corporate names and trade names mentioned in this catalog are trademarks or registered trademarks.