

Quality is more than a word

ESPEC

Conductor Resistance Evaluation System

AMR-U



Continuous measurement of micro resistance in solder joint and connector contact areas. Accurate evaluation of the reliability of connections

The Conductor Resistance Evaluation System enables continuous measurement of resistance changes under high and low temperature cycles.

Automatic measurement, data storage and processing are operated systematically with a PC.

The system realizes accurate and effective contact reliability evaluations.

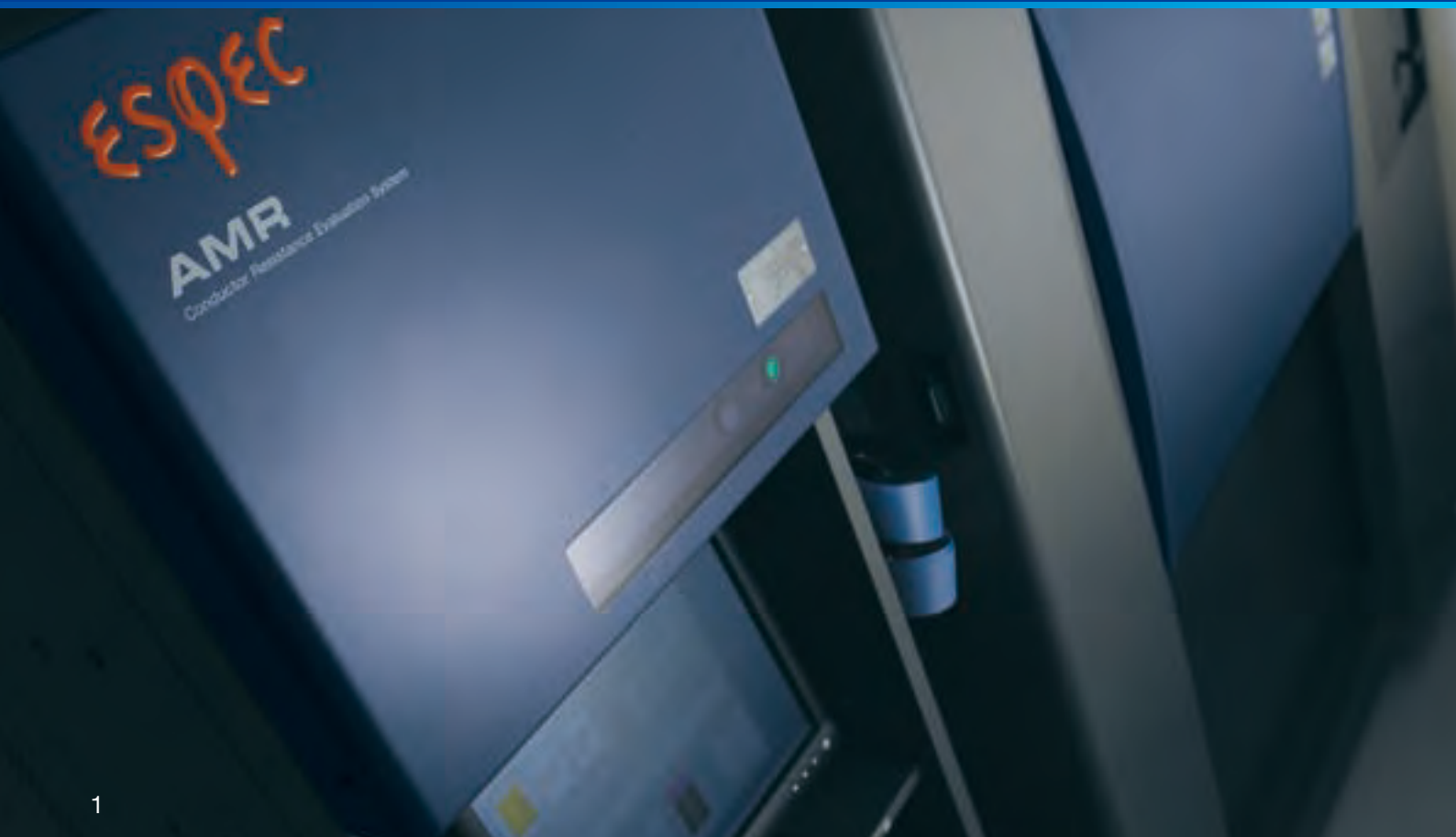



Accurately detects minute cracks in semiconductor packages and electronic component junctions. Automatic measurement and chamber integration allow improved efficiency in test schedule management.

● Solder crack progression



Example of AMR connected with a Thermal shock chamber

● Main features

- Unique multi-scan and international standards-compatible measurement equipment.
- Both direct and alternating current application available.
- Absolute value and changing rate evaluation available.
- Real time measurement enabled using a personal computer.
- Editing/ browsing of data available during the evaluation process.
- Test efficiency dramatically improved by thermal shock chamber's interaction with the AMR.

● Evaluation targets

- Printed circuit boards
- Semiconductor underfill

● Main applications

- Through-hole conductor evaluation
- Solder-joint contact evaluation
- BGA, CSP solder joint contact evaluation
- Connector contact resistance evaluation
- Fpc life evaluation
- Contact resistance evaluation of switches, Relays, etc.
- Lead-free solder joints evaluation
- Contact resistance evaluation of Connectors, etc.
- Conductive adhesives and anisotropic conductive films evaluation
- Other interconnection material contact evaluation

● Models

- With DC application (AMR-UD)
Resistance measurement range: 10^3 to 10^6
Minimum resolution: 100
- With AC application (AMR-UA)
Resistance measurement range: 10^3 to 10^4
Minimum resolution: 10

Using an international standard traceable precision instrument guarantees the most accurate and compatible measurement data.

- **We have always known how to earn our customers' confidence**

AMR is equipped with highly reliable measurement equipment and an ammeter for micro-electric current both designed to meet international standards. This, to obtain most reliable measurement data. We offer a calibration service to maintain the equipment's accuracy.
(ISO / IEC 17025 compliant)

- **We offer two equipments allowing all possibilities**

We offer two micro electric current applications, the DC (AMR-UD) and the AC (AMR-UA), which are used to flow current to specimens when measuring the conductor resistance.

- **We offer a wide range of resistance measurement; From 10^{-3} to $10^6\Omega$**

Conductor resistance values ranging from 10^{-3} to $10^6\Omega$ (AMR-UD) and from 10^{-3} to $10^4\Omega$ (AMR-UA) can be precisely determined at the tip of a measuring cable, using a four terminal sensing.

- **We offer multi-channel evaluations, thus increasing time-saving and test accuracy**

Channels can be added in 40-channel blocks from the standard 40 channels up to 280 channels (optional) depending on the tests and the number of chambers to be connected.



AMR



Measurement equipment (Agilent Technologies)

Multifunction rack that pursues ease of use improve the workability.



System rack

● Connection unit

Installing the connection unit facilitates the measurement cable connection. The connection unit can be installed in front of the rack, or either on the left or right side of the rack according to the work environment.

● Optimum characteristics cable

The cable supplied is made from Teflon, which guarantees an excellent resistance to noises, as well as heat. Moreover, it enables an optimum/ accurate measurement of micro resistances. The end of the cable is designed to facilitate the connection to a specimen.

● Global environmental issues

Components are fixed with lead-free soldering. Furthermore, power consumption has been reduced by 24% (compared to the previous model) in consideration of global environmental protection.

*except for purchased items such as PCs and measuring instruments.



Connection unit



Measurement cable (Chamber sold separately)

Tests simplified by the interaction of the measurement system with various environmental test chambers.

● Interaction with the environmental test chamber

The AMR can be connected to three environmental test chambers for testing. Interaction with the environmental test chamber enables temperature and humidity monitoring, management of the time schedule, and it displays an alarm when a failure is detected.

● Real-time monitoring of temperature and humidity

AMR monitors and records the temp. and humid. inside the environmental test chamber. Data are recorded simultaneously with the measurement carried out by the AMR. The statistics processing software displays the recorded data in synchronization with the data of the resistance tests.

● Safety design guaranteed by abnormality detection

If a failure occurs with the environmental test equipment or the AMR, the test will stop immediately. Resetting will resume the test from where it stopped.

● Remote processing of the test data (optional)

LAN-compatible software enables remote test checking and data processing, for example from a distant office. Additionally, we offer software licenses according to the number of users so that multiple PC monitoring is possible.



Example of AMR connected with a Thermal shock chamber

Function	Interaction with the thermal shock chamber (TSA Series)
Temperature monitoring	Loads temperature data for each measurement are processed by the AMR. Data are saved on a CSV format.
Cycle count	Analyzes the cycles performed by the chamber, by counting and failure occurrences listing.
Start of the test	The AMR starts the test automatically, as soon as the chamber parameters has been set.
Halt of the test	The AMR automatically stops operations of both itself and the chamber, after being exposed to high temperature.
Resumption of the test	Automatically resumes the halted cycle of the test as it is. The halt history is saved in the measurement data.
Completion of the test	Test automatically ends when the test is completed.
Work temperature monitoring	The AMR take temperature measures in the chamber (randomly), up to 16 channels. Data are saved in CSV format.
Chamber failure detection	When a failure occurs in the chamber or the measuring equipment fails to operate properly, the test automatically stops.
Data processing	Checks the obtained temperature data against the data of resistance values based on the number of cycles.

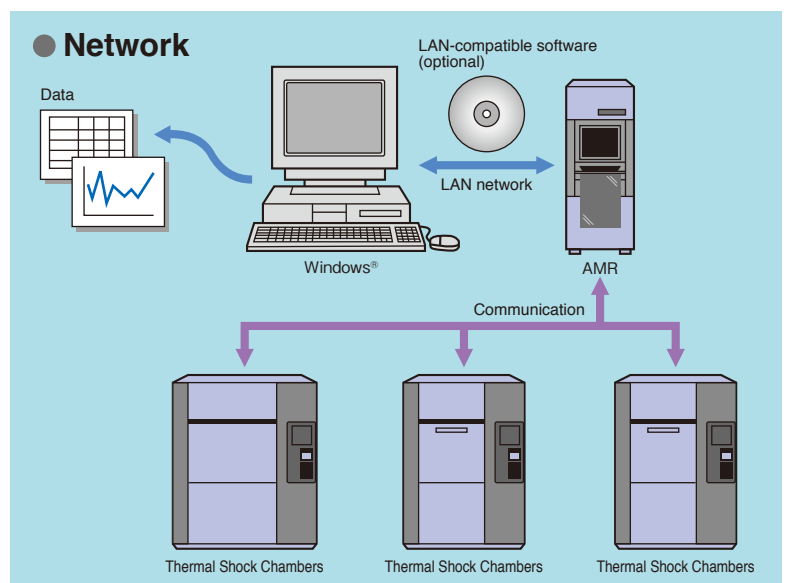

DC or AC measurement can be selected according to your test requirements.

● **Example: reliability evaluation of BGA and CSP solder ball connections (Daisy chain evaluation)**

● **DC and AC application evaluation**

Case in which signals between measured channels do not interfere with each other (communication between channels is independent from each other)

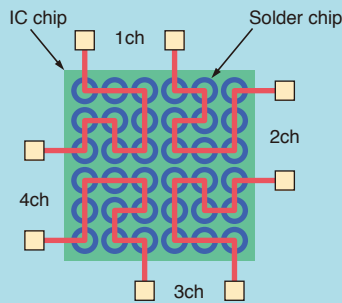

● **DC application only (AMR-UD only)**

Case in which the measured signals interfere with each other between channels

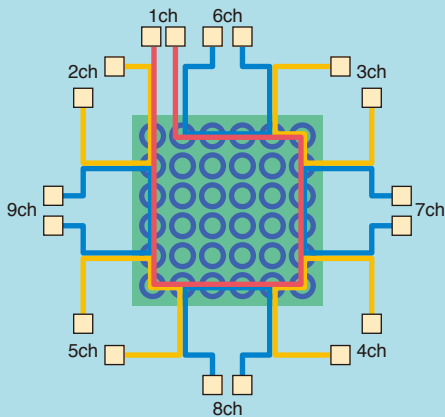

* Compatible model differs depending on the daisy chain design for BGA and CSP evaluations.

● **DC Measurement (AMR-UD)**

Using DC current resistance to measure small voltage change and detect up to $1M\Omega$ of resistance. It is suitable for the observation of large changes of conductive resistance, such as Daisy Chain of BGA in semiconductor applications.

● **AC Measurement (AMR-UA)**

Using AC micro current to measure small voltage changes without being affected by thermal electromotive force. It is suitable for the observation of changes in conductive resistance evaluations.

Evaluated item	DC application (AMR-UD)	AC application (AMR-UA)
Lead-free solder joints	◎	◎
Reliability of BGA and CSP solder ball connections	◎	○
Contact resistance of connectors, etc.	○	◎
Contact resistance of switches, relays, etc.	△	◎
Conductive adhesive and anisotropic conductive films	◎	◎

Evaluation

Two failure recognition methods can be performed to detect the failure in conductive resistance of the joint parts.

● Failure recognition using the absolute value

The data obtained at measurement intervals are evaluated using the preset absolute value. It will detect small changes of conductive resistance due to micro-cracks, and will do so until total opening of the crack.

Absolute value can be set in hot condition and cold condition to have separate identifications from both temperature ends. The AMR will terminate the test once that failure is identified on the channel. (It can be set to resume the test too.)

● Failure recognition using the change rate (%)

This method can be used to detect small changes of conductive resistance in BGA and CSP. It will compare the initial value at the starting point of the test with the actual one, and will use the % of difference to detect the failure. It can be set on both ends of hot and cold conditions.

● Evaluation with absolute value

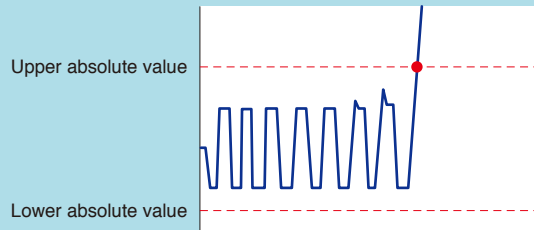

• Evaluation of the measured data using the absolute value.

■ Absolute value setting

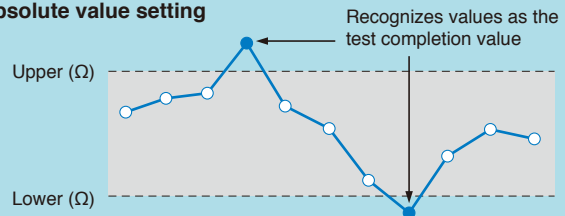

● Evaluation with the change rate

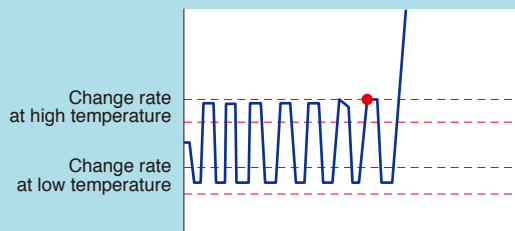

• Evaluation of the measured data using the change rate.

■ Change rate setting

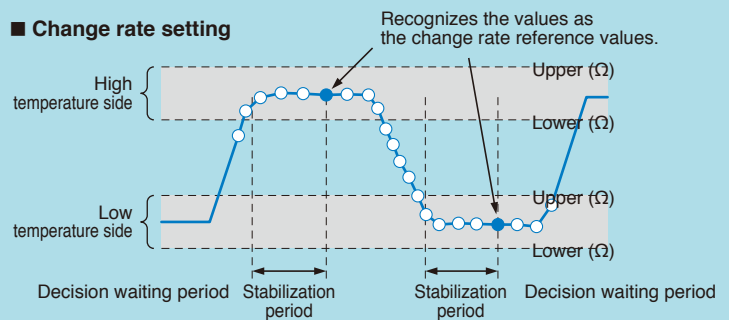

SOFTWARE

● Main window*



- Test monitoring
- Real time display of the resistance value, temperature inside the chamber, channel on which a failure occurs
- Auto link to the data processing software
- Control commands (start, stop, pause, and restart)

* The picture shows AMR-280-UD.

● Test condition registration



Setting of:

- Duration, nb. of cycles of a test
- Duration of the measurement
- Voltage measurement
- Stress application voltage
- Limit values

These settings can be saved in a file that can be use subsequently; numerous test conditions can be saved for different tests and specimens.

● Test setting



Parameters:

- Selection of a module
- Specification of the data file name and the connected chamber
- Text documents output
- Selection /unselection of the leak-touch action mode
- Comments input
- Selection of the channel for the testing
- Test conditions' specifications (Test conditions selected from a saved file)

● Graphic display

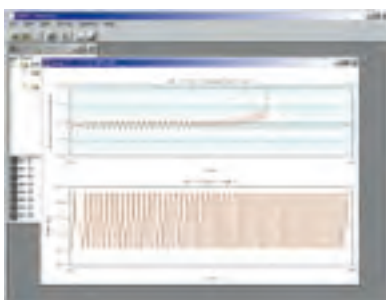

The graph can be arranged by selecting the channel displayed, the settings and the cursor.

Graphs can be copied on a clipboard and opened in another software.

(The sample graph displays a resistance value with the temperature in the thermal shock chamber at the same time.)

● Cursor function



Quick confirmation of measurement data and channel number is available, thanks to the cursor function displayed on the graphic

● Weibull Analysis (Optional)

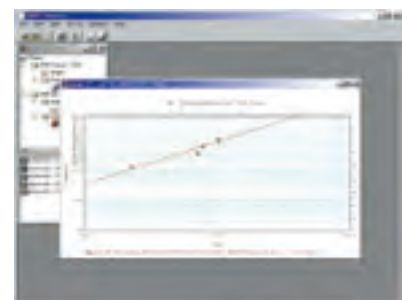

This data-processing software (with a statistic processing function) enables a Weibull analysis of test data, as well as regular probability plotting, and logarithmic probability trend curves.

SYSTEM CONFIGURATION DIAGRAM

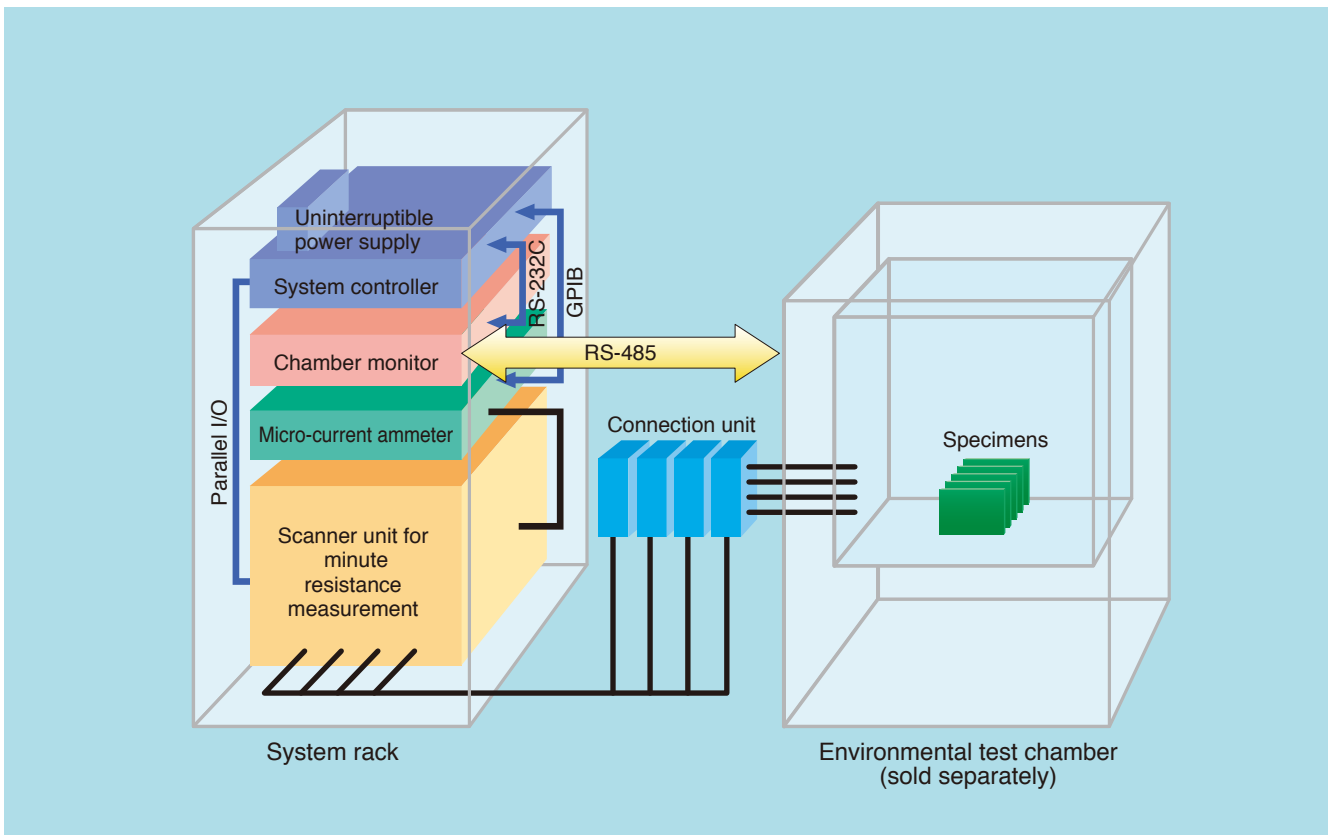

- **System controller :**
PC and LCD monitor for system control.
Measurement, data processing, chamber control.
- **Uninterruptible power supply :**
Backup power supply for the system controller.
Automatically interrupts the test in case of power cut.
When power recovers, the test restarts from where it was stopped. (does not resume automatically)
- **Chamber monitor :**
Allows temperature control, monitoring, alarm control of the chamber from the system controller.
- **Micro-resistance measurement unit :**
Precisely measures resistance by 4-wire (resistance) measurements.
UD type: Equipped with 34420A made by Agilent Technologies
UA type: Equipped with 4338B made by Agilent Technologies
- **Scanner unit for minute resistance measurement :**
40 standard channels
(Optionally, up to 280 channels can be added)
- **Connection unit :**
Relays the measurement cable.

SPECIFICATIONS

Model		AMR-040-UD	AMR-040-UA
Current application		DC application	AC application
Channel configuration		Standard 40ch. (max. 280ch per rack)	
Control channel		A unit of 10 channels	
Software		Windows 7	
Measurement	Measuring intervals	Minimum 3 seconds (10 channels), Variable in 3-sec. steps	
	Resistance measurement range	1×10^{-3} to $1 \times 10^6 \Omega$	1×10^{-3} to $1 \times 10^4 \Omega$
	Minimum resolution	$100\mu\Omega$	$10\mu\Omega$
	Measurement accuracy *1	10 mΩ Measured value of $\pm 5\%$ or less	
	Measurement range	1Ω, 10Ω, 100Ω, 1kΩ, 10kΩ, 100kΩ, 1MΩ, and AUTO	10mΩ, 100mΩ, 1Ω, 10Ω, 100Ω, 1kΩ, 10kΩ, and AUTO
Measurement cable	Type	Heat-resistant flat cable	
	Coated material	Teflon (Temperature for continuous duty: +200°C *2)	
	Length	Beyond connection unit: 1.5m	
Connection cable	Type	Non heat-resistant measurement cable	
	Length	Between scanner unit and connection unit: 2.0m	
Connection unit		One connection unit has 40-channel connection.	
Measurement equipment		Model: 34420A (Agilent Technologies)	Model: 4338B (Agilent Technologies)
External dimension		530W × 1750H × D940D mm	
Power supply facility		100V AC, 1φ, 10.0A 120V AC, 1φ, 8.3A 220V AC, 1φ, 4.5A 240V AC, 1φ, 4.2A	

*1 Value guaranteed at end of measurement cable of a standard system.

*2 The solder used for connections has to be chosen by the customer, regarding its temperature resistance.

MODEL

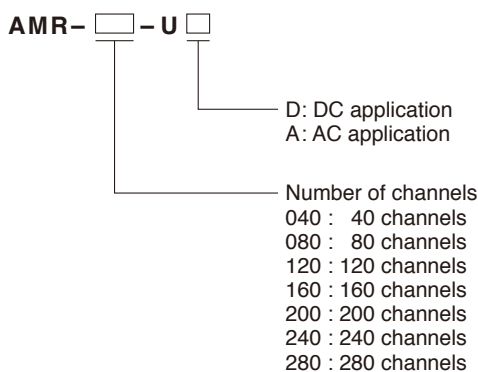

ACCESSORIES

- Measurement cable
- Communication cable (RS-485)
- Setup CD
- User's manual

OPTIONS

Additional channel (40 channel basis)

Heat-resistant measurement cable

Identical to the heat-resistant measurement Teflon cable included as a standard accessory.

- 1.5 m
- 2.5 m
- 3.5 m

* Can be extended in 1 meter increments upon request at the time of purchase.



Colored heat-resistant cable

Provides different colored cables for each channel.

- 1.5 m

* Can be extended in 1 meter increments upon request at time of purchase.

Non heat-resistant measurement cable (extension)

Specimen temperature monitor

Specimen temperature monitor measures the surface temperature of the specimen and saves the specimen surface temperature and the measured data simultaneously. The following two types are available.

- 8 points measurement type
- 16 points measurement type

LAN-compatible software

Data processing software (with statistic processing software)

Emergency stop switch

Stops the system immediately.

Communication cable

Ion Migration Evaluation System **AMI**

Makes stress evaluations and insulation resistance evaluations by electrochemical migration efficient and easy, and covers a broad spectrum, from low-voltage to high-voltage tests.

■ Evaluation Targets

- Printed circuit boards
- Insulation materials
- Semiconductor materials



Semiconductor Parametric Test System **AMM**

Supports cutting-edge device evaluation and offers highly-reliable data acquisition, collection, and analysis over a wide range of evaluation conditions from reliability evaluations to test/characteristic evaluations.

■ Evaluation Targets

- Semiconductor transistors
- Low-k materials
- High-k materials



Electromigration Evaluation System **AEM**

Space-saving all-in-one system, the AEM is the only product of its kind in the industry to offer electromigration evaluation of $1\mu\text{A}$ at 400°C .

■ Evaluation Targets

- Semiconductor wiring patterns
- Solder bumps



Flash Memory Endurance Cycling System **RBM-LCT**

A Monitored Burn-in System for evaluation testing of non-volatile memory, such as Flash memory or FeRAM. This testing/evaluation equipment is suited to a variety of uses from R&D to mass production.

■ Evaluation Targets

- Flash memory (FeRAM and MRAM)



VARIOUS ENVIRONMENTAL TEST CHAMBERS (SOLD SEPARATELY)



Thermal Shock Chamber TSA Series

TSA series is the series that reduces the temperature recovery time, temperature heat-up time, and temperature pull-down time. TSA series has HFC refrigerant and a touch-panel that facilitates operation setting changes.

TSA Series is presented as environment-friendly series.

Model	Temperature range	Inside dimensions (mm)
TSA-71S	High temp. chamber: +60 to +200°C Low temp. chamber: -70 to 0°C	W410×H460×D370
TSA-101S		W650×H460×D370
TSA-201S		W650×H460×D670
TSA-41L	High temp. chamber: +60 to +200°C Low temp. chamber: -65 to 0°C	W240×H460×D370
TSA-71L		W410×H460×D370
TSA-101L		W650×H460×D370
TSA-301L		W970×H460×D670



Thermal Shock Chamber TSD-100

TSD-100 is a thermal shock chamber with two zones that conforms to Japanese and international test standards such as MIL-STD-883, JIS C 0025 and JASO-D001. With excellent temperature distribution performance, this chamber applies uniform temperature stress to specimens. Furthermore, by monitoring specimen temperature with the STT function, this chamber starts counting exposure time and switches to the next step immediately after the specimen temperature reaches a preset value, thus enabling highly accurate tests. In the temperature range between 60 and 150, this chamber has a short return time of 15 minutes, allowing a reduction of the total test time. This chamber can be used in a variety of purposes, from research and development to inspection and production.

Model	Temperature range	Inside dimensions (mm)
TSD-100	High temp. chamber: +60 to +200°C Low temp. chamber: -65 to 0°C	W710×H345×D410

ESPEC CORP. <http://www.espec.co.jp/english>

Head Office

3-5-6, Tenjinbashi, Kita-ku, Osaka 530-8550, Japan
Tel: 81-6-6358-4741 Fax: 81-6-6358-5500

ESPEC NORTH AMERICA, INC.

Tel: 1-616-896-6100 Fax: 1-616-896-6150

ESPEC EUROPE GmbH

Tel: 49-89-1893-9630 Fax: 49-89-1893-96379

ESPEC ENVIRONMENTAL EQUIPMENT (SHANGHAI) CO., LTD.

Head Office

Tel: 86-21-51036677 Fax: 86-21-63372237

BEIJING Branch

Tel: 86-10-64627025 Fax: 86-10-64627036

TIANJIN Branch

Tel: 86-22-26210366 Fax: 86-22-26282186

GUANGZHOU Branch

Tel: 86-20-83317826 Fax: 86-20-83317825

SHENZHEN Branch

Tel: 86-755-83674422 Fax: 86-755-83674228

SUZHOU Branch

Tel: 86-512-68028890 Fax: 86-512-68028860

ESPEC TEST TECHNOLOGY (SHANGHAI) CO., LTD.

Tel: 86-21-68798008 Fax: 86-21-68798088

ESPEC (MALAYSIA) SDN. BHD.

Tel: 60-3-8945-1377 Fax: 60-3-8945-1287



ISO 9001/JIS Q 9001
Quality Management System Assessed
and Registered

ESPEC CORP. has been assessed by and registered in the Quality Management System based on the International Standard ISO 9001:2008 (JIS Q 9001:2008) through the Japanese Standards Association (JSA).

ISO 14001 (JIS Q 14001)
Environmental Management System Assessed and Registered
ESPEC CORP.

- Specifications are subject to change without notice due to design improvements.
- Corporate names and trade names mentioned in this catalog are trademarks or registered trademarks.